

PLEASE READ THESE INSTRUCTIONS CAREFULLY BEFORE INSTALLATION
PLEASE RETAIN INSTRUCTIONS FOR FUTURE REFERENCE



Emergency Pack Installation Instructions



IMPORTANT PLEASE READ BEFORE INSTALLATION

- Before commencing installation ensure the electricity is switched off at the mains.
- Installation should be carried out in accordance with the latest edition of the I.E.E. Wiring regulations (BS7671) taking into account the latest building regulations.
- Installation should be carried out by a qualified electrician.
- Ensure all electrical connections are tight with no loose strands, including factory made connections.

WARNINGS

- Do not connect the battery into the circuit until a permanent 230V unswitched supply can be assured.



The luminaire and EM pack terminals may remain live, even when the lamp is not operating.

- Isolate the mains supply.
- Connect driver to luminaire.
- Connect the switched mains supply to the appropriate LED driver observing mains wiring precautions. Live wires or connectors must not be left exposed.
- Connect the un-switched supply to the corresponding terminals of the emergency pack.
- Carefully switch on the mains supply.
- Connect the battery.
- Charge the battery fully for a minimum of 24 hours before carrying out testing procedure.

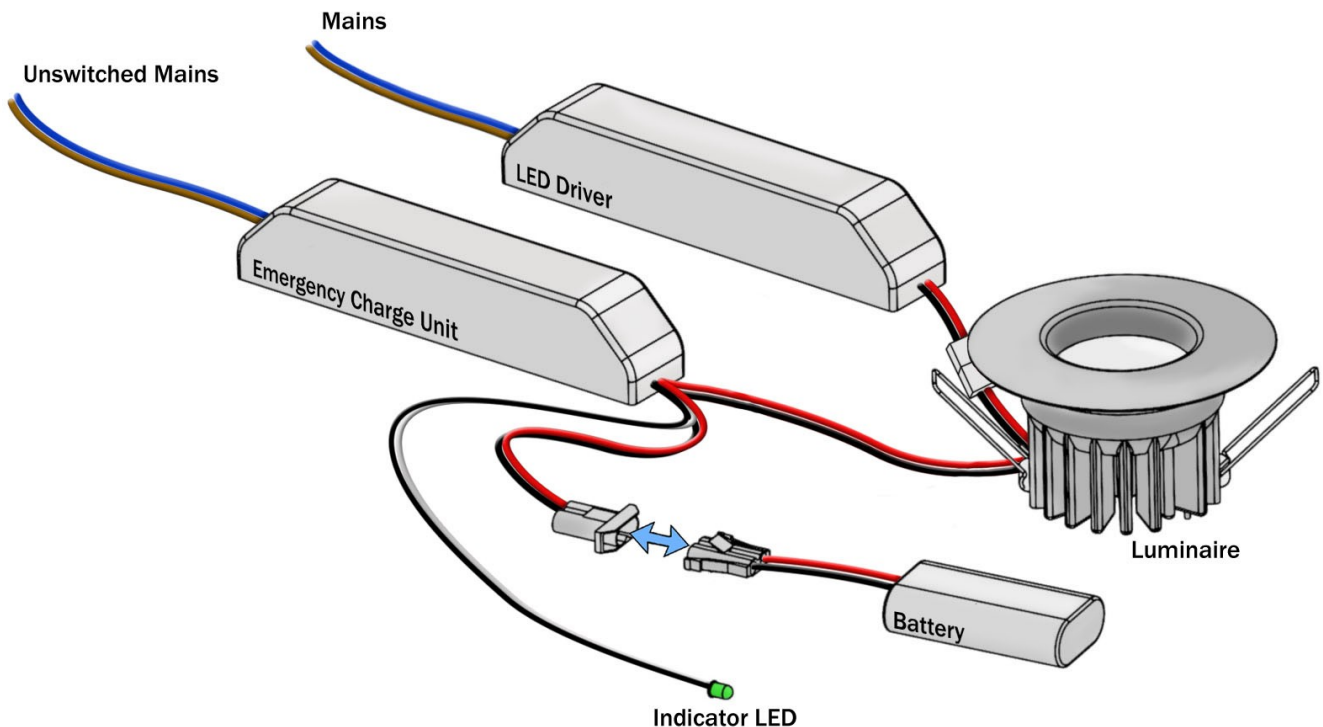

Photonstar LED Group plc
Unit 8, Westlink,
Belbins Business Park
Romsey
Hampshire
SO51 7JF

Tel: 0845 519 7717
Email: ecostar@photonstarled.co.uk
Web: www.ecostar.photonstarlighting.co.uk