



# Lorem SM

## Installation Instructions



### IMPORTANT PLEASE READ BEFORE INSTALLATION

- Before commencing installation ensure the relevant mains supply has been safely isolated.
- Installation should be carried out in accordance with the latest relevant wiring regulations for the specific country/region.
- Installation should be carried out by a qualified electrician.
- Ensure all electrical connections are tight with no loose strands, including factory made connections.

### WARNINGS

- Use only with the approved driver for this product.
- This luminaire is for indoor use only.
- **IMPORTANT** The LED driver must not be covered by ceiling insulation material; this will reduce the units operational lifetime, invalidate the guarantee and may cause a risk of fire.

This install manual covers the following products:

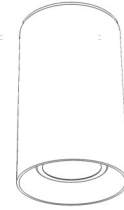

LR-SM-MW/xxx-  
xxx-xx-xx/xx

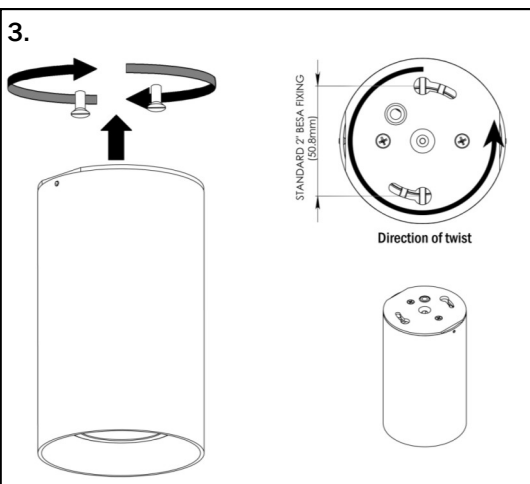
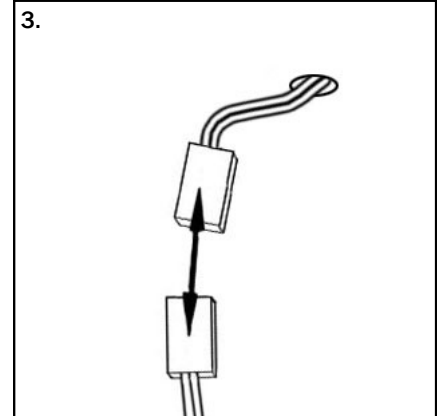
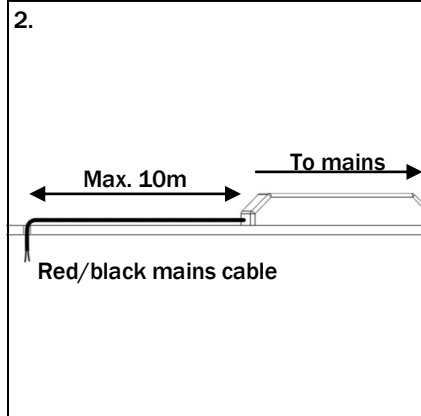
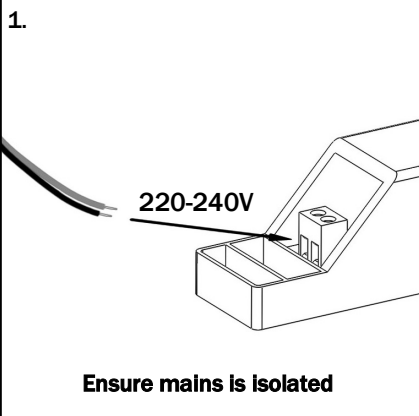

### For screwing directly to ceiling:

- Connect LED driver to mains
- Locate LED driver up to 10m away from fitting and feed connector through ceiling.
- Connect luminaire to LED driver.
- Locate appropriate fixing screws at 2"/50.8mm centres. Do not tighten fully, however there should be sufficient friction between the screw heads and the keyhole slots to hold the fixture in position.
- Use a clockwise twist to secure the luminaire to the screws.
- Tighten screws if necessary.

Photonstar LED Ltd.  
Unit 8, Westlink,  
Belbins Business Park  
Romsey  
Hampshire  
SO51 7JF  
UK

Tel: +44(0) 2381 230 381  
Email: [info@photonstarled.com](mailto:info@photonstarled.com)  
Web: [www.photonstarlighting.com](http://www.photonstarlighting.com)



PLEASE READ THESE INSTRUCTIONS CAREFULLY BEFORE INSTALLATION  
PLEASE RETAIN INSTRUCTIONS FOR FUTURE REFERENCE

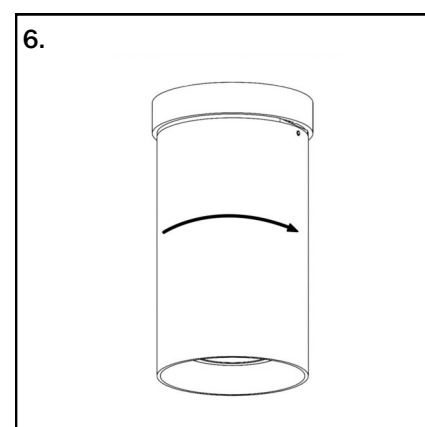
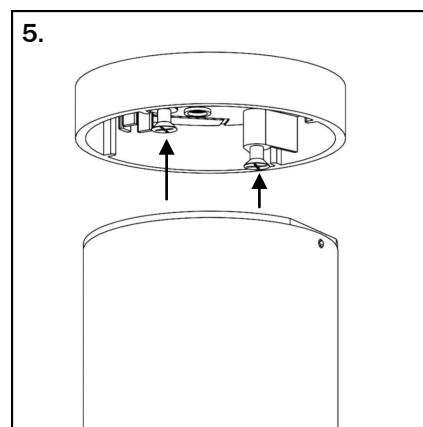
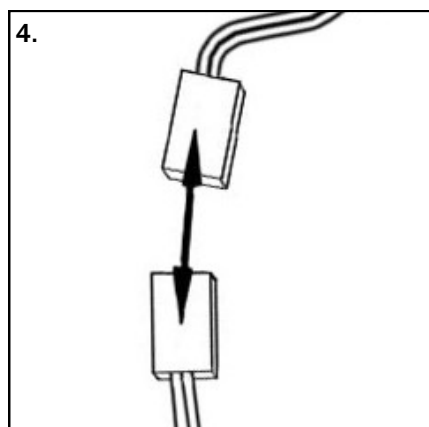
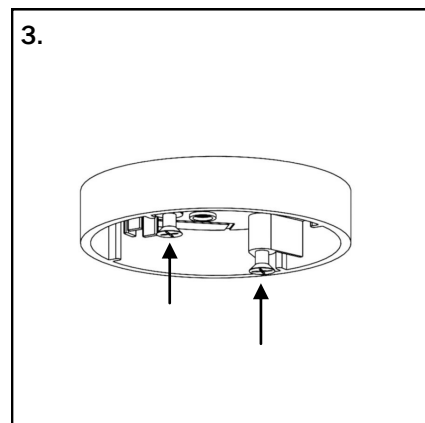
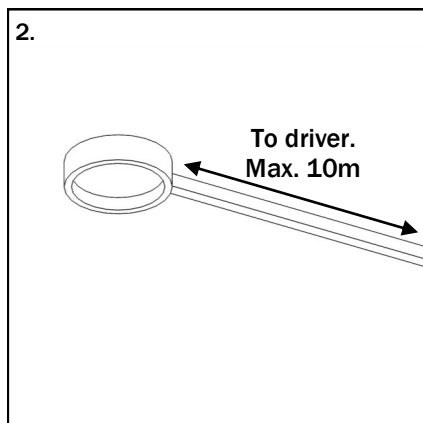
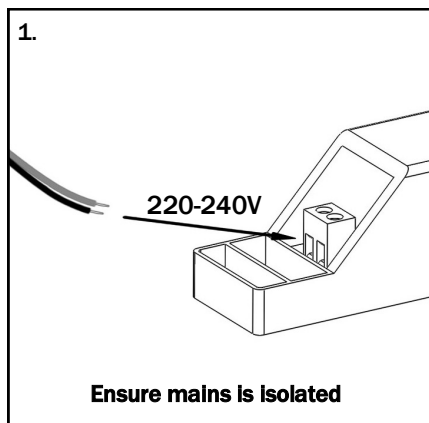

**For conduit (BESA) box with 2"/50.8mm centres:**

- Connect driver to mains.
- House LED driver up to 10m from fitting and feed wire through conduit to conduit box.
- Locate mounting screws in conduit box
- Connect the luminaire to the LED driver
- Secure the luminaire to the adaptor plate using the two screws and twist clockwise to lock into place.
- Tighten if necessary.

Photonstar LED Ltd.  
Unit 8, Westlink,  
Belbins Business Park  
Romsey  
Hampshire  
SO51 7JF  
UK

Tel: 0845 519 7717  
Email: [info@photonstarled.co.uk](mailto:info@photonstarled.co.uk)  
Web: [www.photonstarlighting.com](http://www.photonstarlighting.com)



P2 of 2  
Revision: 1.12/04/11